

# D2676



## Characteristics

- Cylinders and arrangement: 6 cylinders in-line
- Operation mode: 4-stroke diesel engine, watercooled
- Turbocharging: Turbocharger with charge air intercooler and wastegate
- Number of valves: 4 valves per cylinder
- Fuel system: Common rail injection with high pressure pump
- Engine block: High-strength casting with integrated oil and water ducts and replaceable cylinder liners
- Engine lubrication: Force-feed lubrication, lubrication oil cooler in cooling water circuit of the engine
- Type of cooling: Seawater cooled charge air cooler, plate heat exchanger by rubber impeller pump
- Engine control: Electronic injection control, electronic engine monitoring including diagnostic unit
- Fuel: DIN EN 590

## Technical features

Type designation		LE 432	LE 435	LE 422	LE 425
Displacement	l	12.42	12.42	12.42	12.42
Nominal rating <sup>1)</sup>	kW (hp)	412 (560)	412 (560)	478 (650)	478 (650)
Rated speed	rpm	2,100	2,100	2,100	2,100
Torque at rated speed	Nm	1,869	1,869	2,174	2,174
Maximum torque	Nm	2,065	2,065	2,402	2,402
at speed	rpm	1,200–1,900	1,200–1,900	1,200–1,900	1,200–1,900
Lowest specific fuel consumption	g/kWh	196	204	197	205
Classifiable		✓	✓	✓	✓
Exhaust gas status		IMO Tier II, 97/68/EC	IMO Tier II, EPA Tier 3, RCD 2013/53/EC, 97/68/EC	IMO Tier II, 97/68/EC	IMO Tier II, EPA Tier 3, RCD 2013/53/EC, 97/68/EC

1) Rating according to DIN 3046-1

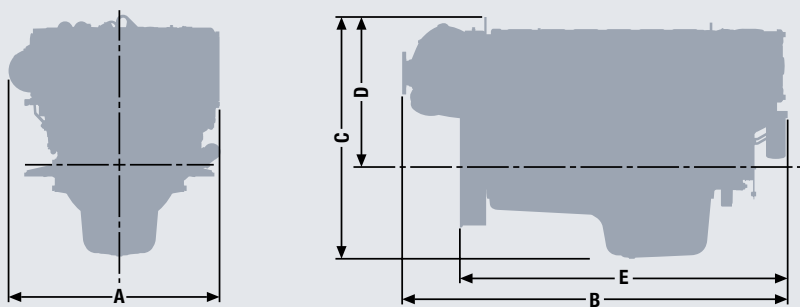

## Dimensions

Type designation		LE 432/435/422/425
A-Overall width	mm	986
B-Overall length	mm	1,795
C-Overall height	mm	1,096
D-Top of engine to crankshaft centre	mm	674
E-Length of engine from front end to edge of flywheel housing	mm	1,527
Average weight of engine ready for installation (dry)	kg	1,215

For detailed examinations of installation dimensions, please order drawings from our factory.

# D2676

D2676 LE 432

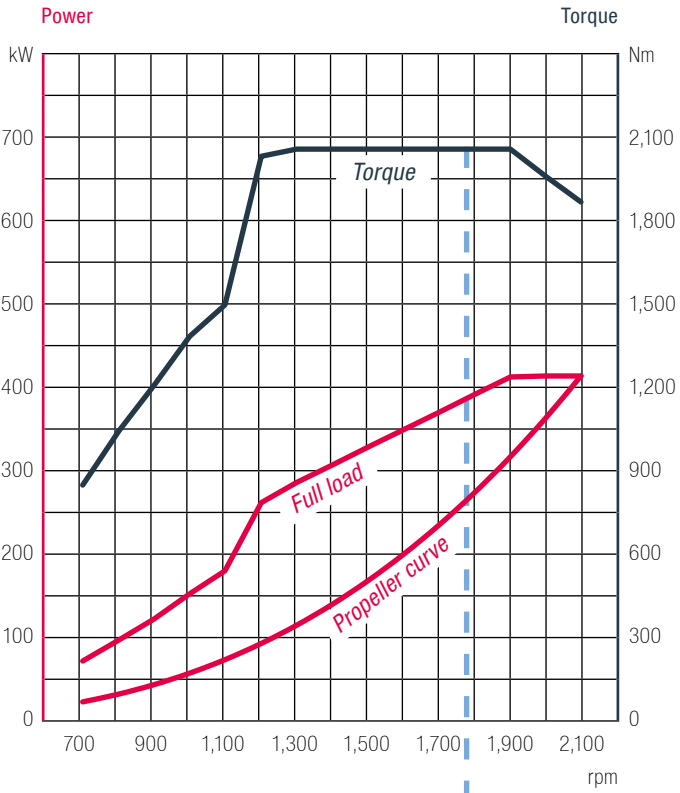

D2676 LE 435

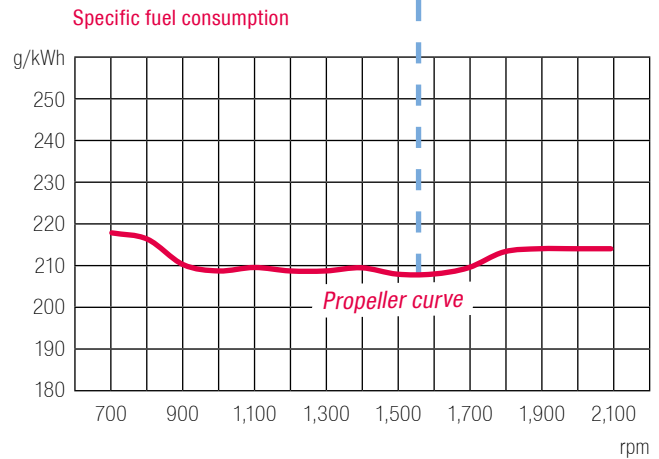
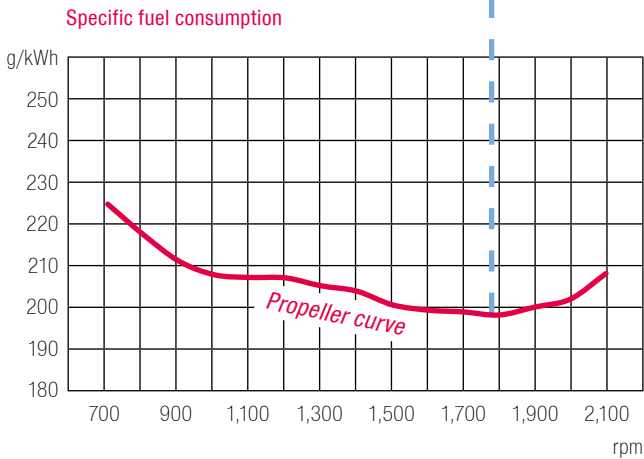
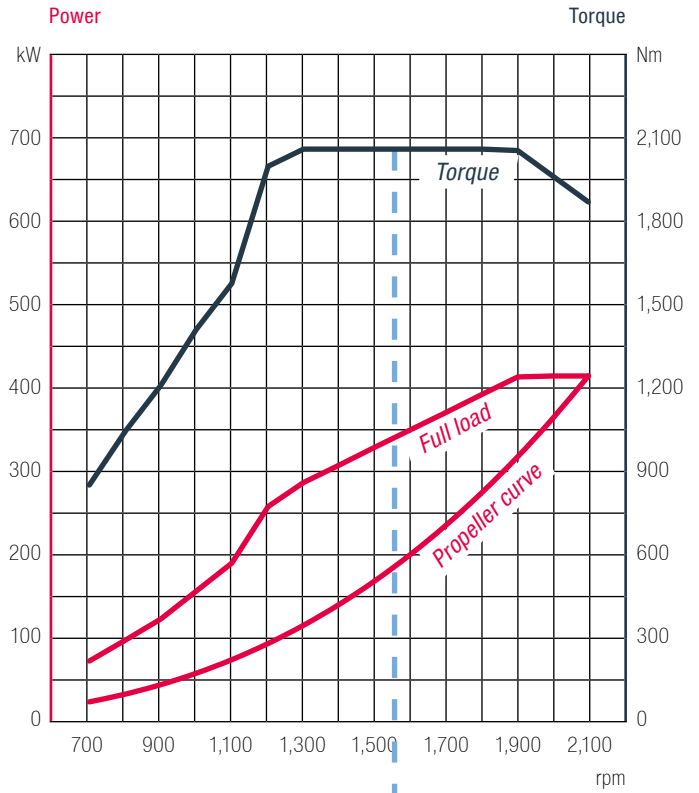

--- Maximum torque at most fuel efficient operating point

D2676 LE 422

D2676 LE 425

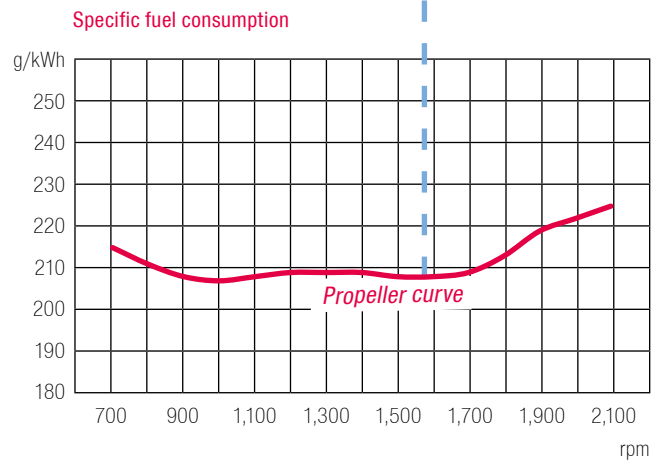
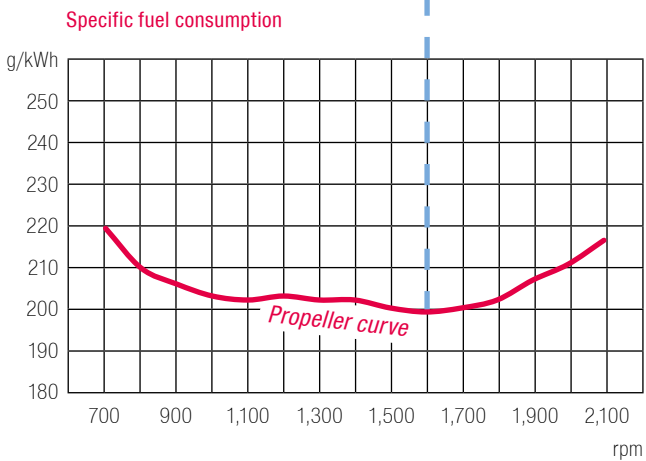
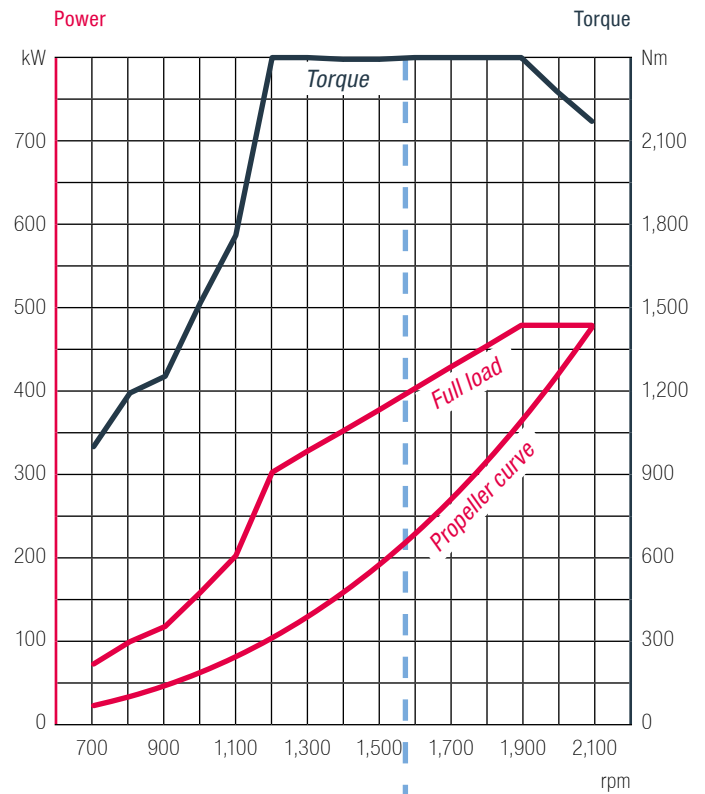
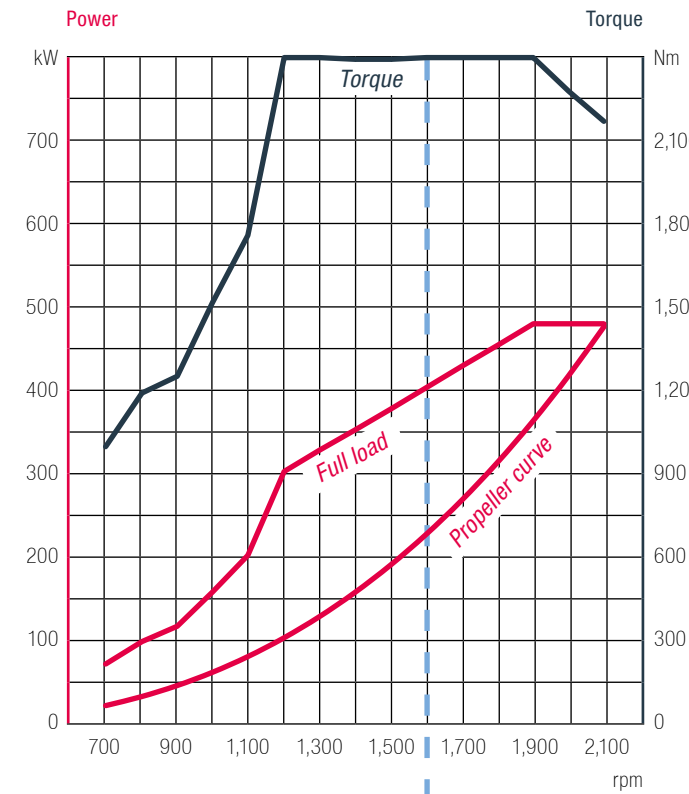

--- Maximum torque at most fuel efficient operating point